



LAIMA™



INDUSTRIES PVT. LTD.

THINK DIFFERENT, FEEL DIFFERENCE



RIBBON BLENDER MACHINE

Specification :-

MOC : MS

Models : 250 Ltr. To 10000 Ltr.

Working Volume

Batch Capacity in KG

125 Kg to 5000 Kg @ of 0.5 BD



Use For :

Any Kind Of Dry Powder

AN ISO 9001 : 2015 Certified Company



RIBBON BLENDER MACHINE

Specification :-

MOC : S.S. 304 / 316

Models : 100 Ltr To 10000 Ltr

Working Volume

Batch Capacity in KG

50 Kg to 5000 Kg @ of 0.5 BD



Use For :

Any Kind Of Dry Powder

AN ISO 9001 : 2015 Certified Company



RIBBON BLENDER MACHINE

Specification :-

MOC : M.S. / Contact S.S. 304

Models : 750 Ltr To 15000 Ltr

Working Volume

Batch Capacity in KG

500 Kg to 10000 Kg @ of 0.7 BD

Use For : Rice Only.



AN ISO 9001 : 2015 Certified Company



SCREW CONVEYOR

SPECIFICATION :-

MOC : M.S. & S.S. 304 / 316

Size Range : Dia 6" to 36"

Direct Gear Drive / Couple Drive

Type : U Type & Pipe Type

Hanger Attachment Every 3 Mtr. Length

Stand as per Inclination And Length

Wheels extra on Demand

Standard Hopper Provide : 50 Ltr. with Slide Gate & Grill

Use For :

Solid / Semi Solid Particals, Granual,
Powder, & Many More....



AN ISO 9001 : 2015 Certified Company



BUCKET ELEVATOR

Specification :-

MOC : M.S. , S.S. 304

Type : Box And Twin Leg

Size Range : As Per Requirement

Bucket Size Range : 4" To 12"

Gear Motor Drive

Canvas Belt

Working Platform & Monkey Leader

Extra For More Than 3 Mtr. Height

Use For :

Any Kind Of Powder And Grain



Box Type



Twin Leg Type

AN ISO 9001 : 2015 Certified Company



BELT CONVEYOR

Specification :-

MOC : M.S.

Size Range : Customize As Per Requirement

Type : Horizontal, Incline, Through Type

Drive : Gearbox And Motor / Gear Motor

VFD Control Panel Extra For Speed Variant.

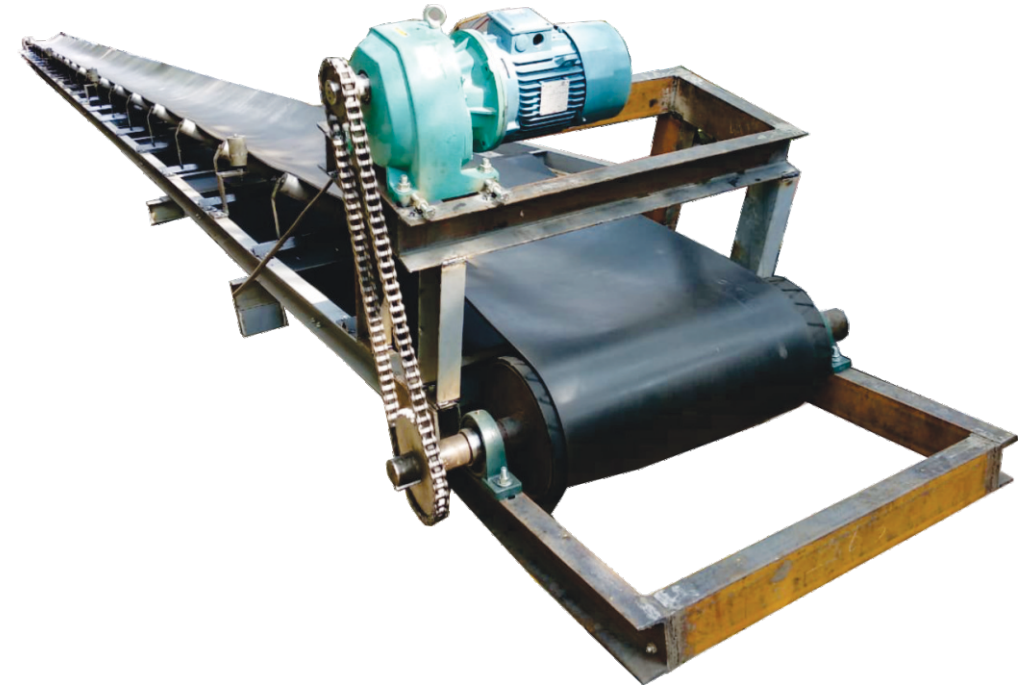

Use For :

Any Kind Of Material Handling

AN ISO 9001 : 2015 Certified Company



VIBRO SCREEN

Salient features :

- Continuos Operation
- Low Power Consumption
- Maintenance Free
- Easy to Operate
- Simple Operation for screen Change
- One Or More Particle Size Screening
- Extra :** Ball Tray Arrangement for Fine Particle



Model	LIPL - 600	LIPL -750	LIPL -900	LIPL -1200	LIPL -1500	LIPL -1800
Machine Size	24"	30"	36"	48"	60"	72"
Motor HP (Single Deck)	0.5	0.5	1	2	3	5

Variant Models Available as follows :

M.S., S.S. 304 Contact Part, Fully S.S. 304, S.S. 316 Contact Part, Fully S.S. 316

Use For : Any Kind Of Flour, Powder & Granues

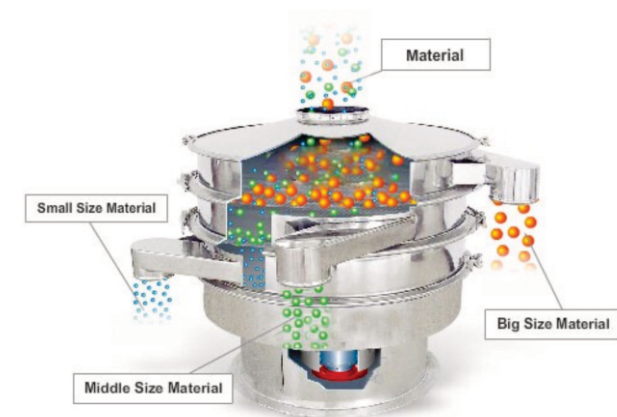

AN ISO 9001 : 2015 Certified Company



LIQUID MIXER

Specification :-

MOC : M.S. , S.S. 304/316

Size Range : 50 Ltr To 5000 Ltr

Gear Motor Drive / Motor Drive

Wheels Extra on Demand

VFD Control Panel Extra For Different Kind of Liquid Mixing.



Use For :

Any Kind Of Liquid

Mixing / Manufacturing

AN ISO 9001 : 2015 Certified Company



BALL MILL (Batch Type)

Specification :-

MOC : M.S. , Contact Part S.S. 304 / 316
& Fully S.S. 304 / 316

Size Range : 100 Ltr To 10000 Ltr

Drive : Gearbox And Motor

Ball : As per Requirement

Liner : As Per Requirement

Use For :

Any Kind Of Powder
And Granules



AN ISO 9001 : 2015 Certified Company



WALL PUTTY MACHINE

Specification :-

Manual Wall Putty Making Machine

Heaving Set Of Three Machines :-

1. Feeding Screw Conveyor
2. Ribbon Mixer
3. Discharge Screw Conveyor

In This Machine We Have
Following Batch Capacity
Machines

1000 Kg, 1500 Kg, 2000 Kg,
2500 Kg, 3000 Kg, 5000 Kg,



AN ISO 9001 : 2015 Certified Company



WALL PUTTY MACHINE

Specification :-

Semi Automatic Wall Putty Making Machine

Heaving Set Of Three Machines :-

1. Feeding Screw Conveyor
2. Ribbon Mixer
3. Packing Machine

In This Machine We Have
Following Batch Capacity
Machines

1000 Kg, 1500 Kg, 2000 Kg,
2500 Kg, 3000 Kg, 5000 Kg,



AN ISO 9001 : 2015 Certified Company



WALL PUTTY PLANT

Specification :-

Fully Automatic Wall Putty Making Plant

Heaving Following Machines :-

1. Feeding Screw Conveyor
2. Ribbon Mixer
3. Discharge Screw Conveyor
4. Bucket Elevator
5. Storage Silo
6. Vibrating System
7. Rotary Air Lock Valve
8. Packing Machine
9. Electrical Panel

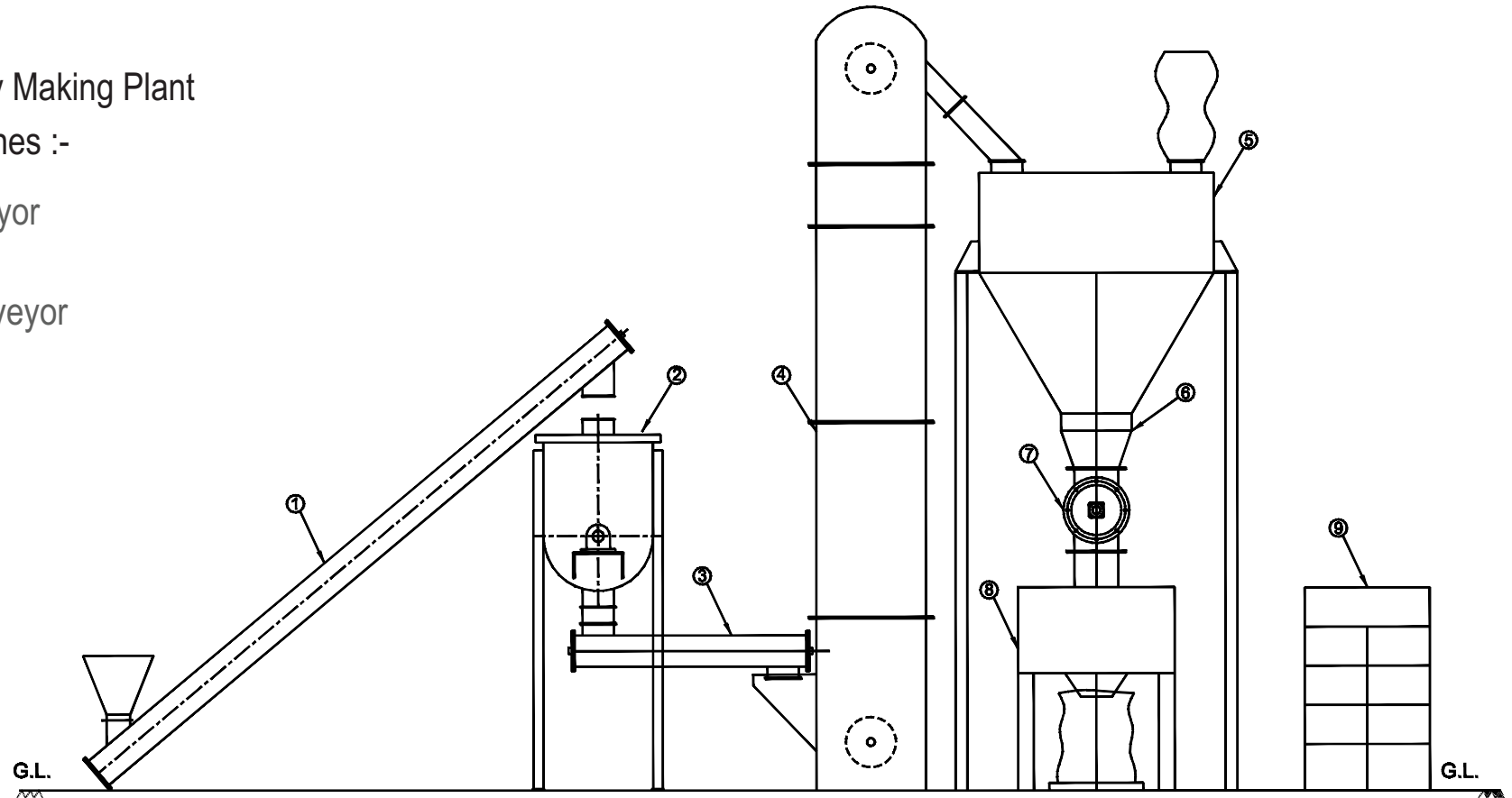

In This Plant We Have

Following Capacity Machines

1000 Kg, 2000 Kg, 3000 Kg, 5000 Kg, Per Hour

AN ISO 9001 : 2015 Certified Company



LIQUID STORAGE TANK

Specification :-

MOC : M.S., S.S. 304 / 316

Size Range : 1000 Ltr. To 50000 Ltr.

Type : Horizontal, Vertical

Use For :

Any Kind Of Liquid



AN ISO 9001 : 2015 Certified Company



GRAINS STORAGE SILO

Specification :-

MOC : M.S., S.S. 304 / 316

Size Range : 5000 Kg To 50000 Kg

Type : Vertical



Use For :
Any Kind Of
Grains & Dry Powder

AN ISO 9001 : 2015 Certified Company



WOOD FIRE WATER HEATER

Specification :-

MOC : M.S.

Size Range : 300 Ltr. To 3000 Ltr.

Wood Fire

Temperature for 80 - 90 Degree

Use For :

Any Kind Of Liquid

Mixing / Manufacturing



AN ISO 9001 : 2015 Certified Company

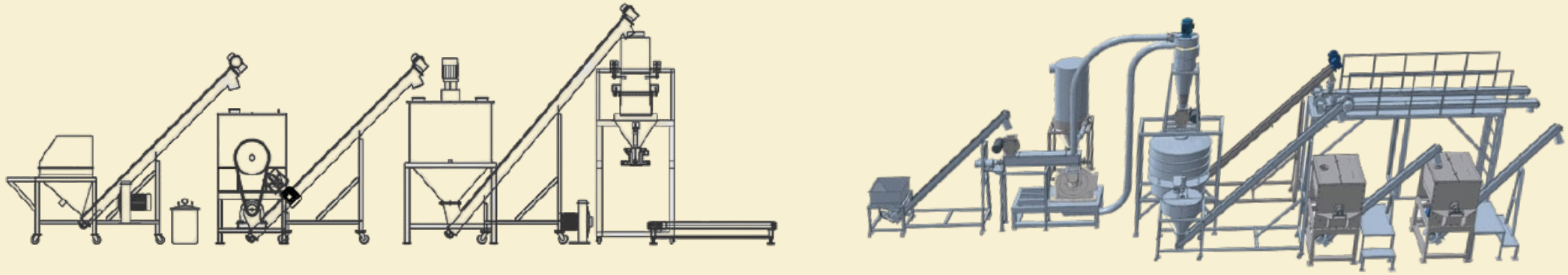

LAIMATM INDUSTRIES PVT. LTD.

📍 A/62, Bileshwar Industrial Estate,
Opp. G.V.M.M., Nr. Odhav Ring Road,
Odhav, Ahmedabad-382415., Gujarat, INDIA

✉ info@laimaindustries.com
laimaindustries20@gmail.com

🌐 www.laimaindustries.com
www.laimaindustries.net

☎ +91 - 9999999999

